

# CGS series

- Chip type with 6.3Ø~16Ø, 125°C, 2,000 hours, long life product.
- Designed For automobile modules and other high temperature applications.
- RoHS Compliance.
- 6.3Ø~16ØV-Chip型, 125°C, 2,000小時長壽命產品。
- 專為汽車模組和其它高溫應用設計。



## SPECIFICATIONS

Items 項目	Characteristics 特性								
Capacitance Tolerance 靜電容量誤差	± 20%(120Hz,20°C)								
Operating Temperature Range 適用溫度範圍	-55 ~ +125°C								
Rated Voltage Range 額定電壓範圍	6.3 ~ 100VDC								
Capacitance Range 靜電容量範圍	1 ~ 4700µF								
Leakage Current 洩漏電流	I ≤ 0.01CV or 3(µA) , which is greater. ( After 3 minutes application of DC rated voltage, at 20°C)								
Dissipation Factor 散逸因素( tan δ)	Measurement Frequency: 120Hz. Temperature: 20°C								
	Rated Voltage(V)	6.3	10	16	25	35	50	63	100
	tan δ(Max)	0.30	0.24	0.20	0.16	0.14	0.14	0.12	0.10
Low Temperature Stability 低溫特性 Impedance Ratio(Max) 阻抗比率(最大值)	Measurement Frequency: 120Hz.								
	Rated Voltage(V)	6.3	10	16	25	35	50	63	100
	Z(-25°C)/Z(20°C)	4	3	2	2	2	2	2	2
	Z(-40°C)/Z(20°C)	8	6	4	3	3	3	3	3
Load Life 負荷壽命	6.3V~50V:2,000hours (ΦD =6.3mm1,000hours);63V~100V:1,500 hours with application of rated voltage at 125°C								
	Capacitance Change	within ±30% of Initial Value							
	tan δ	300% or less of Initial Specified Value							
	Leakage Current	Initial Specified Value or less							
Shelf Life 放置壽命	The following specifications shall be satisfied when the capacitors are restored to 20°C after exposing them for 1,000 hours 125°C without voltage applied. Before the measurement, the capacitor shall be preconditioned by applying voltage according to them 4.1 of JIS C5101-4.								
	Capacitance Change	Within ± 30% of Initial Value							
	tan δ	300% or less of Initial Specified Value							
	Leakage Current	Initial Specified Value or less							
Resistance to Soldering Heat 焊錫耐熱性	The capacitors shall be kept on the hot plate maintained at 250°C for 30 seconds.				Capacitance Change		Within ± 10% of Initial Value		
	After removing from the hot plate and restored at room temperature they meet the characteristics requirements listed at right.				tan δ		Initial Specified Value		
					Leakage Current		Initial Specified Value or less		
Standards 參照標準	Black print on the case top								

## Frequency Coefficient of Permissible Ripple Current

Capacitance (µF)	Frequency (Hz)			
	100 ≤ F < 1K	1K ≤ F < 10K	10K ≤ F < 100K	100K ≤ F
C ≤ 22	0.50	0.80	0.90	1.00
22 < C ≤ 150	0.65	0.85	0.92	1.00
150 < C	0.70	0.85	0.95	1.00

The endurance of capacitors is reduced with internal heating produced by ripple current at the rate of halving the lifetime with every 5°C rise. When long life performance is required in actual use , the rms ripple current has to be reduced.

# CGS series

**DIMENSIONS(mm)**

Chip Type Fig.1 ØD=6~10mm

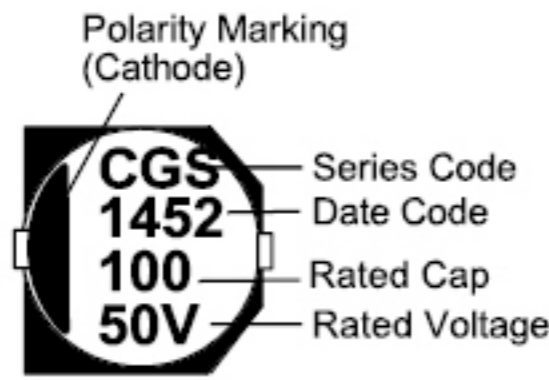
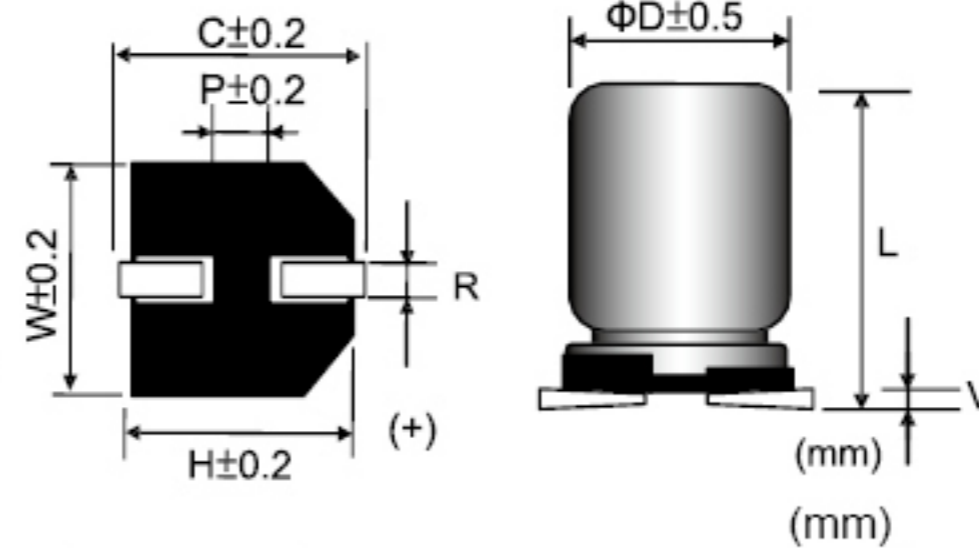
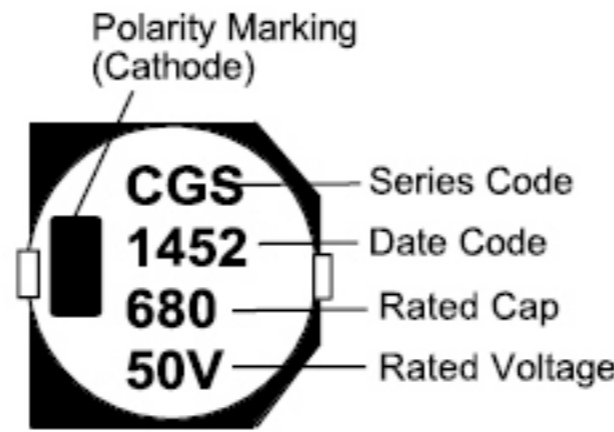

Fig.2 ØD ≥ 12.5mm



Size	ØD	L±0.5	W	H	C	R	P	Vmax
6.3×6	6.3	6.0±0.3	6.6	6.6	7.3	0.5~0.8	2.1	0.3
6.3×7.7	6.3	7.7±0.3	6.6	6.6	7.3	0.5~0.8	2.1	0.3
8×10	8.0	10.0±0.5	8.3	8.3	9.0	0.7~1.1	3.2	0.3
10×10	10.0	10.0±0.5	10.3	10.3	11.0	0.7~1.3	4.5	0.3
12.5×13.5	12.5	13.5±0.5	13.0	13.0	13.7	1.1~1.4	4.5	0.4
16×16.5	16.0	16.5±0.5	17.0	17.0	18.0	1.4~1.8	6.4	0.4

**STANDARD RATINGS**

D×L(mm) ; R.C.(mA rms) at 125°C 100KHz, IMP(Ω max) at 20°C 100KHz.

Cap (µF)	V	6.3			10			16			25		
		Item	D x L	R.C.	IMP	DxL	R.C.	IMP	D x L	R.C.	IMP	D x L	R.C.
33											6.3x6.0	70	1.6
47					6.3x6.0	70	1.6	6.3x6	70	1.6	6.3x7.7	110	0.90
100	6.3x6.0	70	1.6	0.90	6.3x7.7	110	0.90	8x10	160	0.40	6.3x7.7	110	0.90
					8x10	160	0.40				8x10	160	0.40
220	6.3x7.7	110	0.90	0.40	6.3x7.7	110	0.90	8x10	160	0.40	8x10	160	0.40
					8x10	160	0.40				10x10	220	0.30
330	8x10	160	0.40	0.40	8x10	160	0.40	10x10	220	0.30	10x10	220	0.30
					10x10	220	0.30				12.5x13.5	550	0.12
470	8x10	160	0.40	0.30	10x10	220	0.30	12.5x13.5	550	0.12	12.5x13.5	550	0.12
680	10x10	220	0.30	0.12	12.5x13.5	550	0.12	12.5x13.5	550	0.12	12.5x13.5	550	0.12
1000	12.5x13.5	550	0.12	0.12	12.5x13.5	550	0.12	12.5x13.5	550	0.12	16x16.5	900	0.080
1500	12.5x13.5	550	0.12	0.12	12.5x13.5	550	0.12	16x16.5	900	0.080	16x16.5	900	0.080
2200	12.5x13.5	550	0.12	0.080	16x16.5	900	0.080	16x16.5	900	0.080			
3300	16x16.5	900	0.08	0.080	16x16.5	900	0.080						
4700	16x16.5	900	0.08										

Cap (µF)	V	35			50			63			100		
		Item	D x L	R.C.	IMP	DxL	R.C.	IMP	D x L	R.C.	IMP	D x L	R.C.
1					6.3x6.0	45	3.5						
2.2					6.3x6.0	45	3.5						
3.3					6.3x6.0	45	3.5						
4.7	6.3x6.0	60	2.0	3.5	6.3x6.0	45	3.5						
10	6.3x6.0	70	1.6	2.8	6.3x6.0	50	2.8				8x10	70	1.00
22	6.3x6.0	70	1.6	2.0	6.3x7.7	80	2.0	8x10	100	1.00	8x10	70	1.00
					6.3x7.7	80	2.0				10x10	115	0.80
47	6.3x7.7	110	0.90	0.70	8x10	140	0.70	8x10	100	1	12.5x13.5	350	0.33
					8x10	160	0.40						
100	8x10	160	0.40	0.50	10x10	240	0.50	10x10	150	0.5	16x16.5	500	0.240
					10x10	220	0.30						
220	10x10	220	0.30	0.250	12.5x13.5	490	0.23	12.5x13.5	350	0.250			
					12.5x13.5	550	0.12				16x16.5	500	0.18
330	12.5x13.5	550	0.12	0.18	12.5x13.5	490	0.23	16x16.5	500	0.18			
					16x16.5	800	0.15						
470.0	12.5x13.5	550	0.12	0.15	16x16.5	800	0.15	16x16.5	500	0.18			
					16x16.5	900	0.080						
680.0	16x16.5	900	0.080	0.15	16x16.5	800	0.15						
1000.0	16x16.5	900	0.080										